

M-Sens 2

Online-Moisture Meter
for Solids



CONTENTS	Page
1. System Overview	3
2. Function	4
3. Safety	5
3.1 Regular Use	5
3.2 Identification of Dangers	5
3.3 Operational Safety	5
3.4 Technical Progress	5
4. Mounting and Installation	6
4.1 Delivery Range	6
4.2 Auxiliary	6
4.3 Mounting of the Sensor	6
4.4 Mounting of the Transmitter	10
4.5 Use in Ex Hazard Array	11
5. Electrical Connection	12
6. Commissioning	13
7. Menu Structure of M-Sens 2	15
8. Menu Parameters	17
9. Wiring Example	25
10. Maintenance	26
11. Warranty	26
12. Trouble Shooting	26
13. Technical Data	27

1. System Overview

A complete M-Sens 2 unit consists of the following components:

- Flange (mounting in screw, hopper)
- 1 to 3 sensors with 2 m connecting cable
- Transmitter MME 300 for 2 to 3 sensors in a field housing
- C1-Box for connecting of sensor and transmitter

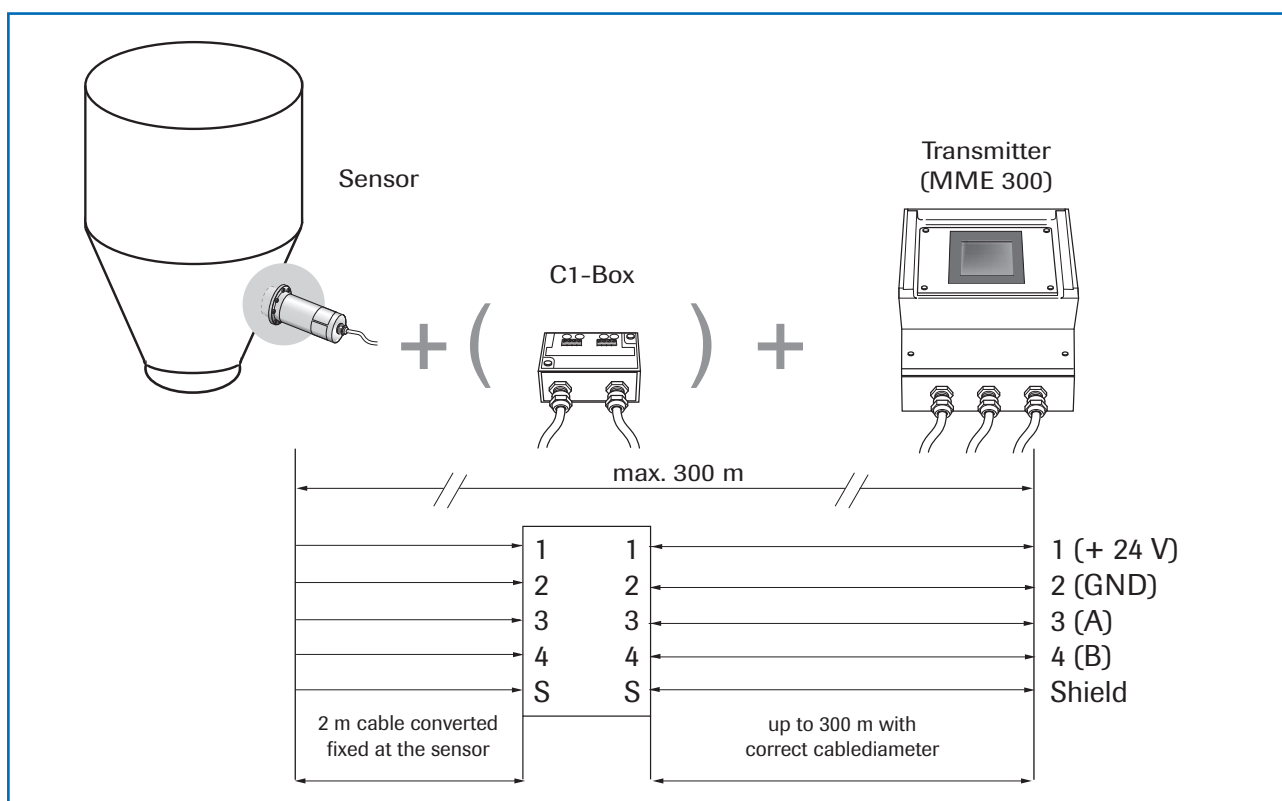

The sensor is connected by a shielded, 4-wired cable to the transmitter; the maximal distance between these devices can be at most 300 m.

2. Function

The M-Sens 2 sensor functionality is based on precise high-frequency measurement and direct digitalization of measured values, where from results a high resolution. As the material surface and capillary moisture influences strongly its specific conductive capacity, the moisture can be measured exactly by a constant averaged bulk density.

The calibration can be done very simply by the operator by pressing the button and entering the referenced moisture contents.

In this context it is convenient that measured value fluctuations by bulk density variations are balanced by an internal filter function. Additionally, measured value fluctuations by temperature variations are compensated automatically by the sensor.

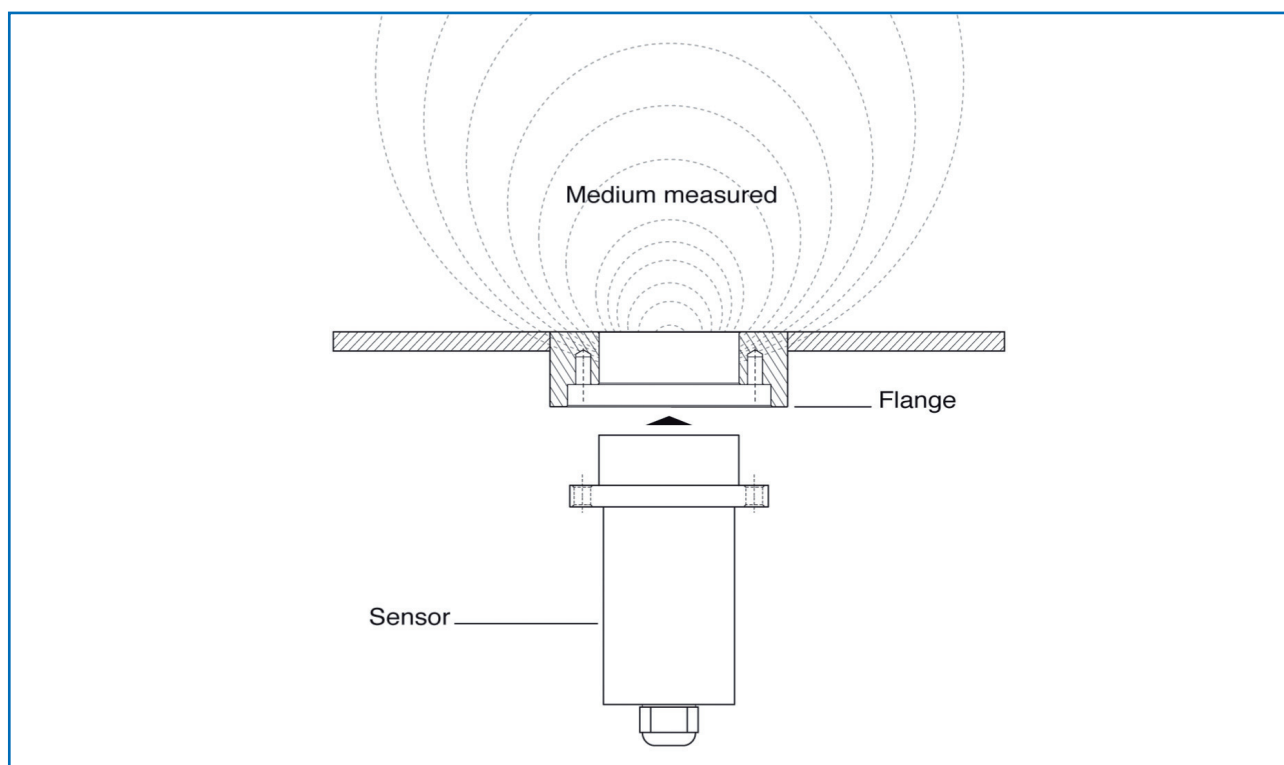

Fig. 2: Injection and reflexion of high frequency

3. Safety

The measuring system M-Sens 2 designed and built according the latest technology has been tested to be safe and was shipped in safe condition. Nevertheless persons or objects may be endangered by components of the system if these are operated in an inexpert manner. Therefore the operational instructions must be read completely and the safety notes must be followed.

In case of inexpert or irregular use, the manufacturer will refuse any liability or guarantee.

3.1 Regular Use

- Only original spare parts and accessories of SWR engineering must be used.

3.2 Identification of Dangers

- Possible dangers when using the measuring system are marked by the following symbols in the operating instructions:



Warning!

- This symbol in the operating instructions marks actions, which may represent a danger for life and limb of persons when carried out in an inexpert manner.



Attention!

- All actions which may endanger objects are marked with this symbol in the operating instructions.

3.3 Operational Safety

- The measuring system must be installed by trained and authorised personnel only.
- In case of maintenance-work on the pipe or on components of the M-Sens 2-sensor, make sure that the piping is in unpressurized condition.
- Switch of the power supply for all maintenance, cleaning or inspection works on the tubes or on components of the M-Sens 2. Follow the notes of the chapter maintenance.
- Before hot-work the sensor must be removed from the installation place.
- The components and electrical connections must be checked for damages regularly. If a damage is found, it is to repaired before further operation of the instruments.

3.4 Technical Progress

- SWR reserves the right to adapt technical data to the technical progress without particular advance notice. If you have any questions, SWR engineering will be pleased to inform you on possible changes and extensions of the operating instructions.

4. Montage and Installation

4.1 Delivery Parts

- Transmitter in the field housing
- Sensor
- Operating instructions
- C1-Box (optional)
- Welding flange

4.2 Auxiliary

- Screw driver 2.5 mm
- Allen key 5 mm

4.3 Mounting of the Sensor

M-Sens 2 is designed for continuous moisture measurement. Most important conditions for correct measurement is the right choice of the mounting place of the sensor. That is, when using chutes or conveyor belts, it is very important to have a almost even material height in front of the sensor window.

- The flange is welded without sensor and dummy plate in the opening at determined mounting place. Sensor and dummy plate are mounting by means of plumbing lubricant. For applications without over-pressure it is possible to renounce the 2 sealing rings.



Attention!

The flange mustn't be welded together with the sensor or dummy plate (incl. the sealing rings).

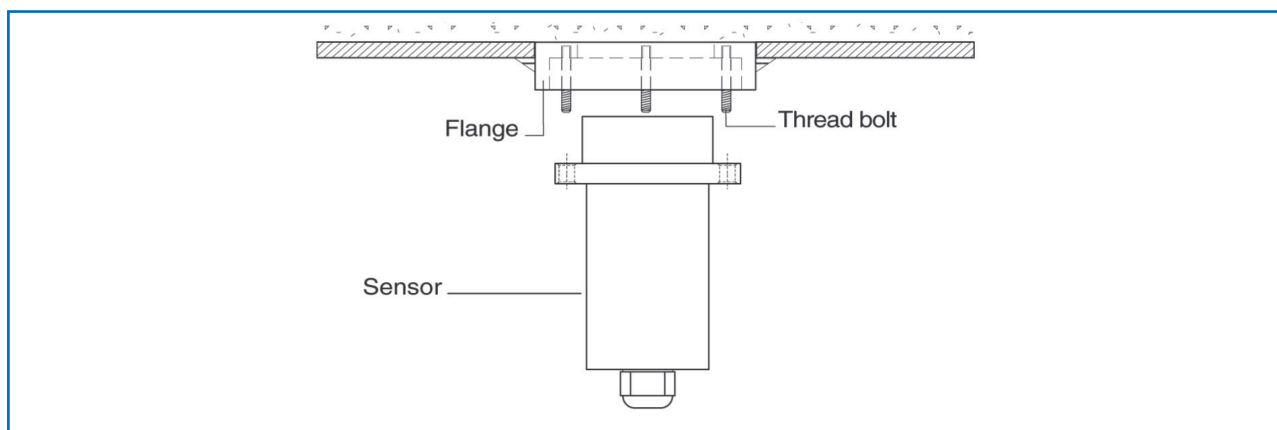

APPLICATIONS - PRACTICAL EXAMPLES**• Installation in a screw**

The installation of a moisture sensor in screw feeders proved to be very advantageous, since the material passes by the sensor window in even intervals and with relatively constant bulk density.

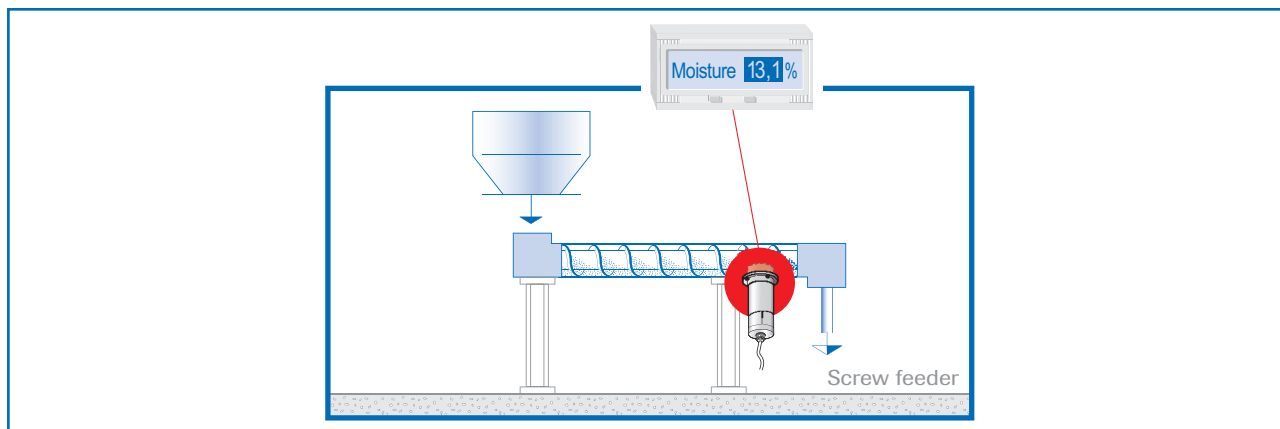
**• Installation on a conveyor belt**

By means of the online moisture measurement of solids on a conveyor belt, the operator can react in due time if the material is too humid or too dry. In consequence, plugging of subsequent aggregates can be prevented.

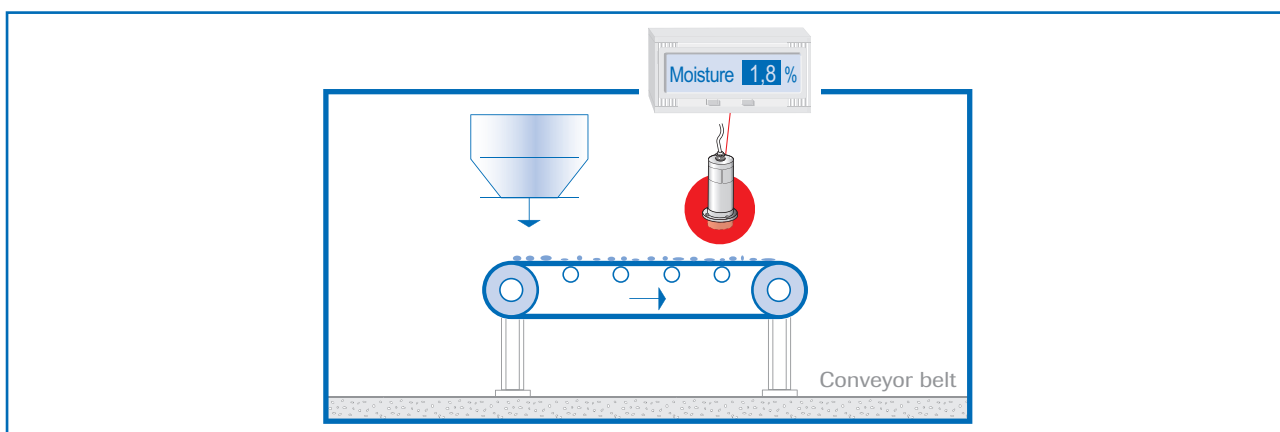

- **Installation in a bin**

Another installation alternative is to mount a sensor at a bins outlet. Due to constant bulk density in case of a filled bin, the sensor finds an almost unchanging measuring field for monitoring the residual moisture. Thus, M-Sens 2 avoids that too damp material reaches the next production level or arrives into the loading.

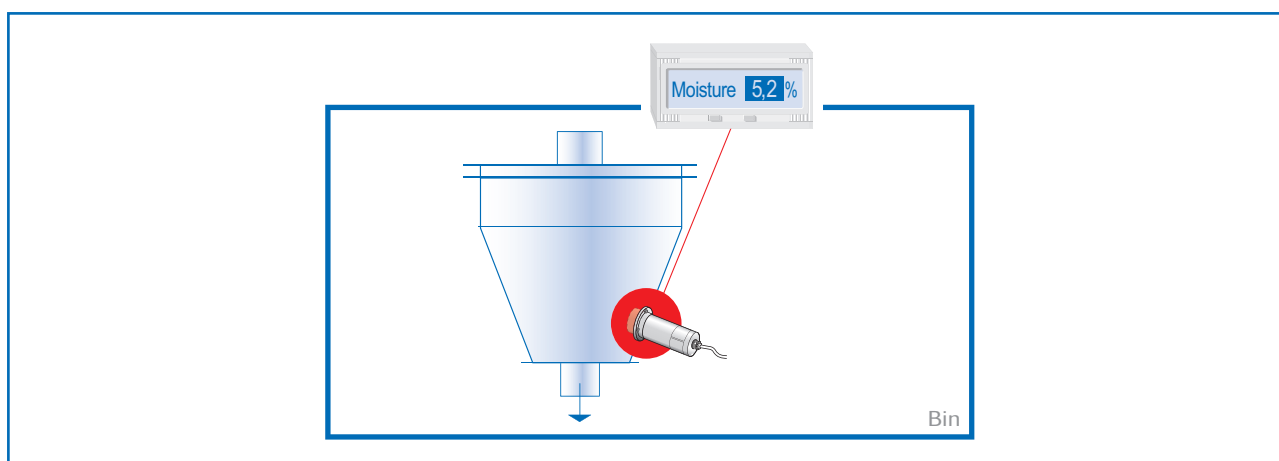

- **Control of dryer by means of moisture measurement**

After the material, lying on the belt, has passed through the dryer tunnel, it gets withdrawn from the hot air zone. At the end of the belt the dried material falls in a screw conveyor which transports it to the processing.

The operator queries the following points: Has the material reached really the desired residual moisture value? That is, has he chosen the right cycle time and temperature?

M-Sens 2 provides accurate and reliable online moisture values for the process control, by which constant moisture in close tolerances of the output material can be met.

This process optimization enables the operator to manage high savings and quality improvements.

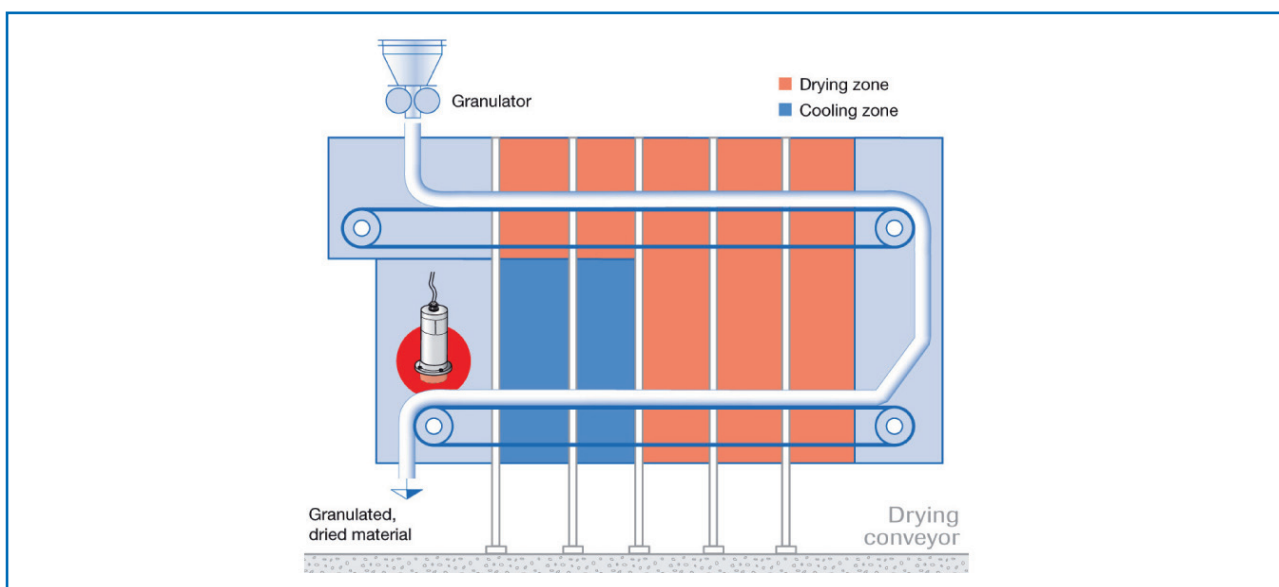

- **Moisture measurement in a mixer**

M-Sens 2 can be installed, even later on, in all types of mixers. The measuring values logging is done by within the moving material during the mixer procedure.

With the measured moisture value of the material in the dryer process parameters like detention time and dosage quantity can be controlled.

For this purpose M-Sens 2 is connected to a PLC or another process control system.

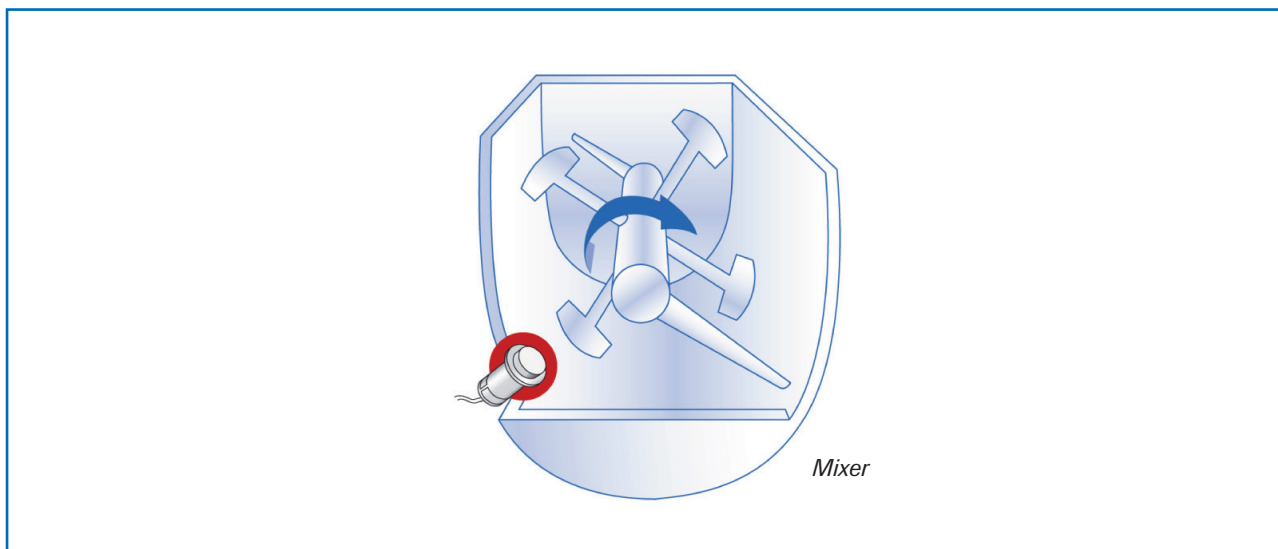

4.4 Mounting of the Transmitter

The whole electronic equipment can be installed at a maximum distance of 300 m from the sensor.
The housing is prepared for wall mounting.

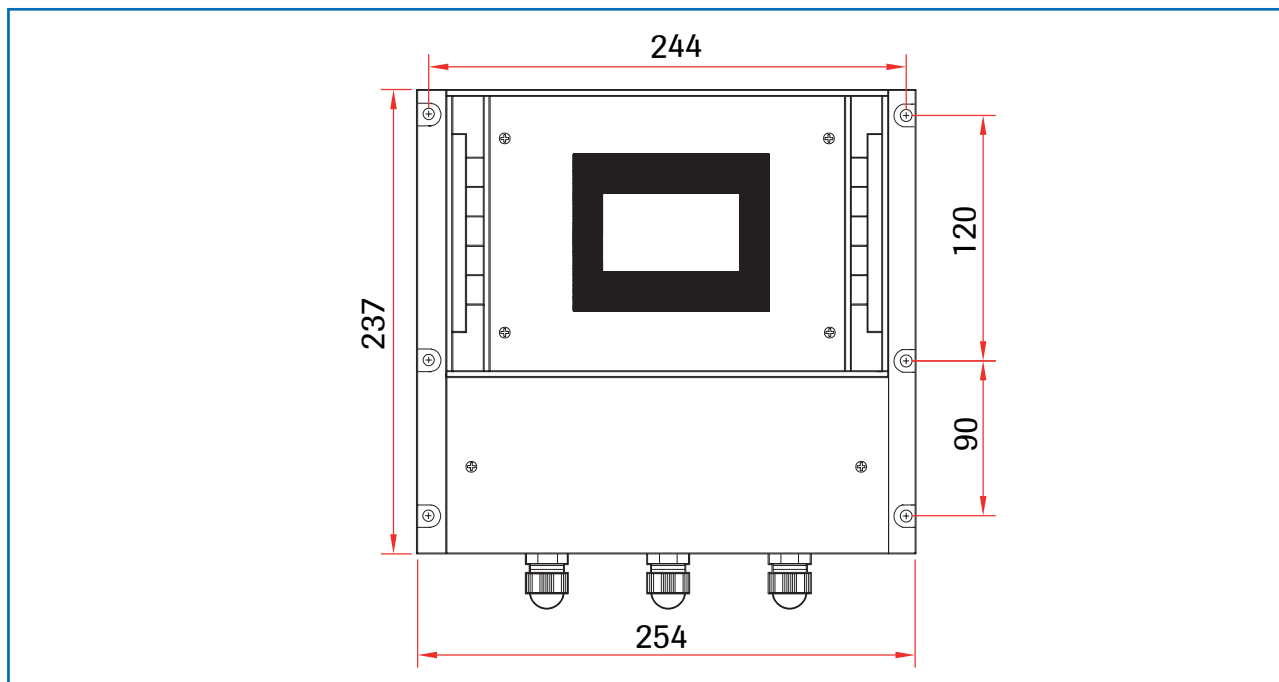

Fig. 9: Field housing for the transmitter

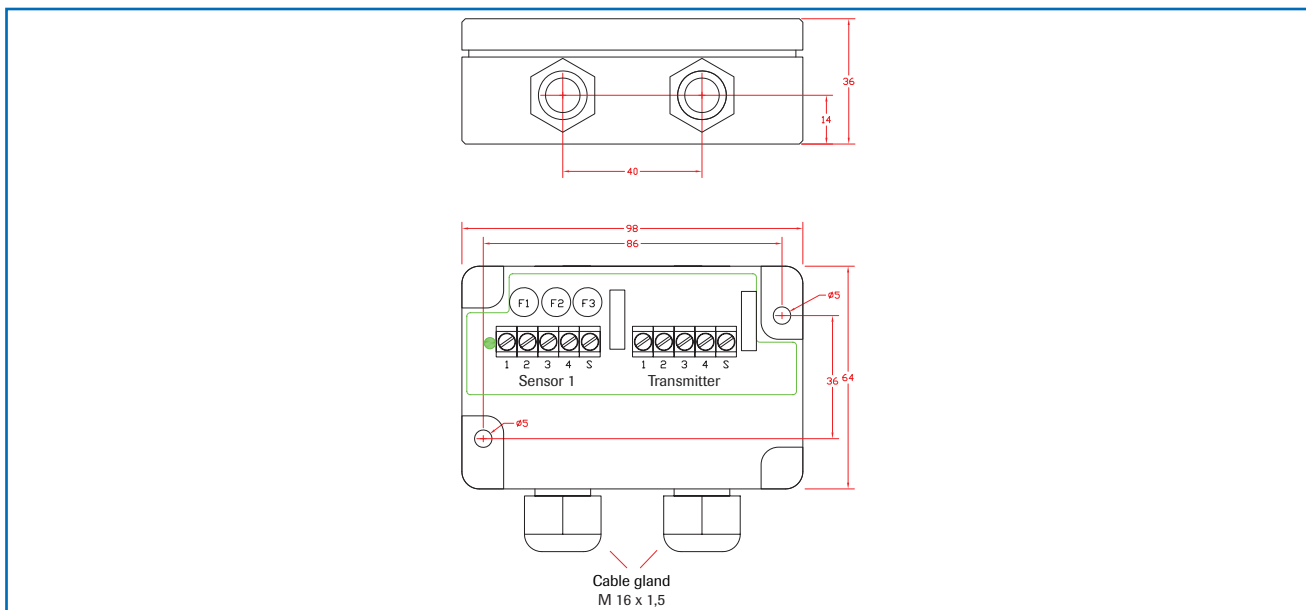

Fig. 10: Field housing for the C1-box

The C1-box contains fuses and resistances in order to guarantee the communication by the ModBus between sensor and transmitter.

4.5 Use in Ex Hazard Area

Marking DustEx:

 II 1D Ex maD iaD 20 T120 °C

- Group of equipment 2
- Equipment category: 1
- Zone 20
- For combustible mixtures from air and inflammable type of dust
- Allowable process temperature 0 ... 80 °C
- Maximum surface temperature 135 °C with $T_a = 60$ °C

Marking GasEx:

 II 1G Ex ma ia CII T4

- Group of equipment 2
- Equipment category: 1
- Zone 0
- For combustible mixtures from air and inflammable type of gas
- Allowable process temperature 0 ... 80 °C
- Maximum surface temperature 135 °C with $T_a = 60$ °C

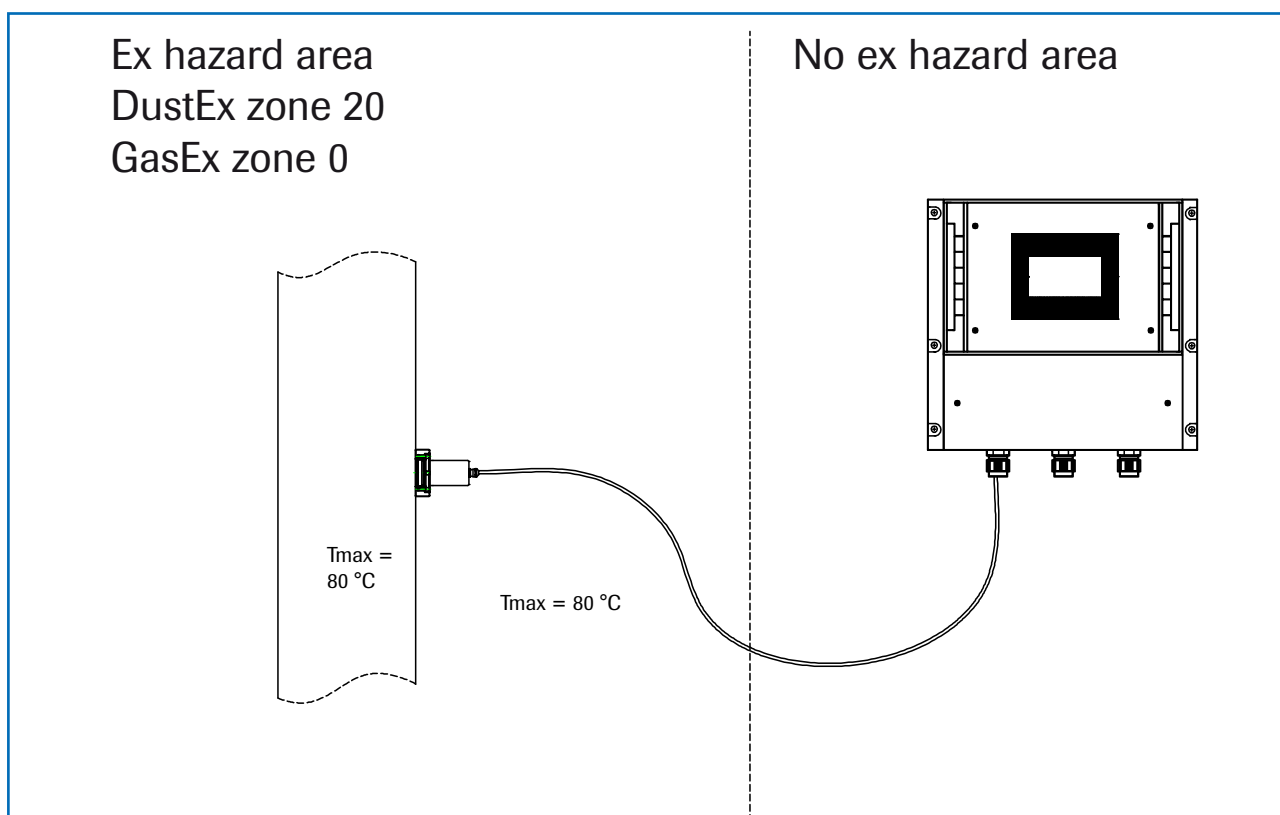

5. Electrical Connection

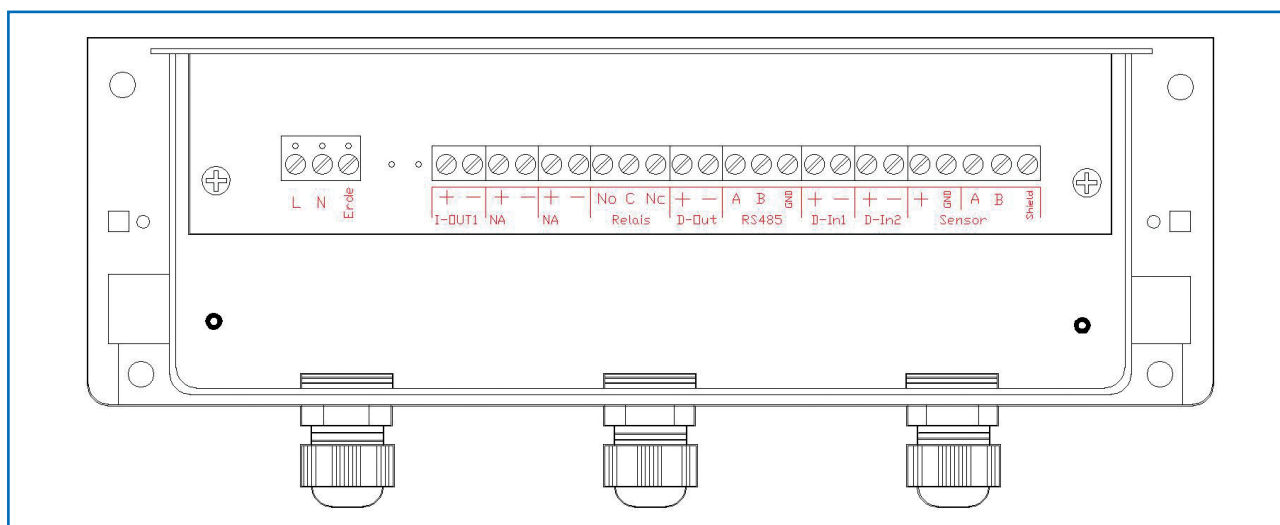

Fig. 12: Electrical connection

Transmitter			
Terminal no.	Connection		
Connection of the power supply			
L / +24 V	Input power supply 230 V / 50 Hz, 110 V / 60 Hz (optional 24 V DC)		
N / 0 V	Input power supply 230 V / 50 Hz, 110 V / 60 Hz (optional 24 V DC)		
PE	Protected earth		
Sensor connection			
I-out1	+	Analogue output +	
	-	Analogue output -	
	Na	Not available	
	Na	Not available	
	Na	Not available	
Min. / Max.- relay	NO	Potential-free relay NO (Close)	
	C	Potential-free relay C (Common conductor)	
	NC	Potential-free relay NC (Open)	
D-out	+	Digital output +	
	-	Digital output -	
RS 485	A	RS 485 intersection data A	
	B	RS 485 intersection data B	
	GND	RS 485 intersection ground	
D-in1	+	Digital intersection 1 (+)	
	-	Digital intersection 1 (-)	
D-in2	+	Digital intersection 2 (+)	
	-	Digital intersection 2 (-)	
Sensor	+	Power supply + 24 V	Cable no. 1
	GND	Power supply 0 V	Cable no. 2
	A	RS 485 data A	Cable no. 3
	B	RS 485 data B	Cable no. 4
	Shield	Shield	

6. Commissioning

At the first commissioning of the M-Sens 2 it is necessary to calibrate the sensor.

Please consider:

- Correct connection between sensor, C1-box and transmitter.
- Correct installation of the sensor in respect to the wall thickness.

In case of negative results in spite of consideration of the points as stated above, please contact SWR.

Commissioning of the M-Sens 2

After the delivery the sensor is **not calibrated to the product(s)**, so each calibration and parameterization has to be executed during the commissioning. Therefore it is necessary to assign the measured moisture to the desired display and to the initial value. The menu functions are very self-explanatory. In the following a short introduction to the menu overview:

Changed values are confirmed and saved by pushing the arrow button. To abandon the menu without saving the changes push the C-button.

Starting the menu

Entering the menu takes place by pushing 5 s the invisible key lower right corner of the touch screen panel.

Basic function

For the measurement and display of the moisture in %, there 2 - 3 moisture measurement executed with known and different moisture values. After having entered the according moisture values by the panel, the system calculates the moisture in % on the basis of those measurement values.

Hereby the basic function is initiated.

Adjustment

The menu point 1 "products" can be used for every of the 4 possible products.

Alarm

Alarm can be determined for every product in the menu point "measurement range".

Analogue outputs

The analogue outputs can be defined in menu point 5. They can be adapted to the operator's requirements (e. g. 0 - 20 mA).

The output value (current) is assigned to the measurement range.

Standard MIN = 4 mA
 MAX = 20 mA

The measurement range filter serves to the adjustment to slower measuring devices or to continuous output at the analogue output.

Digital Inputs	Under menu point 3 you define the digital inputs. Every digital input can be used to start and stop the moisture measurement. Alternated the digital inputs can be used for change of 4 different products.
Basic points	The measurement can be checked for linearity by means of varying moisture values. To improve the accuracy those values have to be determined. If there are deviations the non existent linearity can be corrected / levelled by means of the use of more than 2 base points.
System	Settings according language, time, temperature of sensor and LCD contrast. The communication with the transmitter by ModBus, address and data rate is done according to the system settings. Adjustment of the ModBus by entering the baud rate and address. Adjustment of the ergonomics by setting the contrast and lightning time.

In the following there is the menu structure:

7. Menu Structure of M-Sens 2

1. Products		Products 1 to 4
1.1 Measurement range		
1.1.1	Product name	Choice of material (8 char)
1.1.2	Unity	Choice unit text, e. g. % H ₂ O / % TS
1.1.3	Decimal place	Decimal place position
1.1.4	Measurement range init	Range of 0 ... 100 %
1.1.5	Measurement range end	Range of 0 ... 100 %
1.1.6	Filter value	Range of 0.1 ... 999.9 s
1.2 Alarm 1		
1.2.1	Alarm type	Choose: MIN / MAX
1.2.2	Alarm value	Range of 0 ... 100 % in phys. units
1.2.3	Alarm dead time	Range of 0.1 ... 99.9 s
1.2.4	Alarm hysteresis	Range of 0.1 ... 99.9 %
1.2.5	Operation modus	Choose: Open or closed current principle
1.3. Alarm 2		
1.3.1	Alarm type	Choose: MIN / MAX
1.3.2	Alarm value	Range of 0 ... 100 % in phys. units
1.3.3	Alarm dead time	Range of 0.1 ... 99.9 s
1.3.4	Alarm hysteresis	Range of 0.1 ... 99.9 %
1.3.5	Operation modus	Choose: Open or closed current principle
1.4 Calibration		
1.4.1	Calibration filter	Range of 0.1 ... 999.9 s
1.4.2	Number of calibration points	Range of 2 ... 5 base points
1.4.3	Calibration factor for sensor 1	Rating of sensor signal with several sensors used and disconnecting of 1 sensor with 0
1.4.4	Calibration factor for sensor 2	Rating of sensor signal with several sensors used and disconnecting of 1 sensor with 0
1.4.5	Calibration factor for sensor 3	Rating of sensor signal with several sensors used and disconnecting of 1 sensor with 0

1.4.6	Calibration point 1	Measurement range start and end
1.4.7	Measured value	Record of input value
1.4.8	Calibration point 2	
1.4.9	Calibration	... (depends on the number of the calibration points)
1.4.10	Calibration point N	Measurement range init and end
1.4.11	Measured value	Record of input value

For 2.1 to 2.4 / 3.1 to 3.4 / 4.1 to 4.4 - same way

5. Analogue output

5.1	Beginning of range	Range of 0 ... 22 mA (Standard 4 mA)
5.2	End of range	Range of 0 ... 22 mA (Standard 20 mA)
5.3	MIN limit	Range of 0 ... 22 mA (Standard 3 mA)
5.4	MAX limit	Range of 0 ... 22 mA (Standard 20 mA)
5.5	Alarm value	Range of 0 ... 22 mA (Standard 3 mA)
5.6	Filter time	Range of 0.1 ... 999.9 s (Standard 1 s)
5.7	Calibration: 4 mA	Adjust output current (calibration to 4 mA)
5.8	Calibration: 20 mA	Adjust output current (calibration to 20 mA)

6. Digital inputs

6.1	Digital input 1	
	6.1.1 Function	none / measurement stop or product choice
	6.1.2 Effect direction	direct / inverted
	6.1.3 Filter	Range of 0.1 ... 99.9 s
6.2	Digital input 2	
	6.2.1 Function	none / measurement stop or product choice
	6.2.2 Effect direction	direct / inverted
	6.2.3 Filter	Range of 0.1 ... 99.9 s

7. System

7.1	Baud rate	Choose: 4800 / 9600 / 19200 / 38400
7.2	ModBus address	Range of 1 ... 255
7.3	Contrast	Adjust contrast
7.4	Language	Choose: D / F / E
7.5	Backlight	Backlight Constant = 0 or Delay of Backlight in Minutes Range 1 ... 99 min
7.6	T-display	Sensor temperature display on / off

8. Menu Parameters

1.1 Measurement range

1.1.1 Product name

Select the name of medium and location (max. 8 char).

Choose the characters with \uparrow and \downarrow and the each corresponding position (1 ... 8) with \leftarrow and \rightarrow . With C you clear the character and with \hookrightarrow the input is accepted and you quit the menu level.

Measurement range				\uparrow
Product name				\downarrow
Material				C
	\leftarrow	\rightarrow		\hookrightarrow

1.1.2 Unity

Choice of the measurement value as % H₂O or % TS.

Choose the characters with \uparrow and \downarrow and the each corresponding position (1 ... 6) with \leftarrow and \rightarrow . With C you clear the character and with \hookrightarrow the input is accepted and you quit the menu level.

Measurement range				\uparrow
Unity				\downarrow
% H₂O				C
				\hookrightarrow

1.1.3 Decimal position

Fixation of the decimal position in the display.

With \uparrow and \downarrow you make a choice according to the display. With C you quit the menu point without any change and with \hookrightarrow the input is accepted and you quit the menu level.

Measurement range				\uparrow
Decimal position				\downarrow
000.0				C
				\hookrightarrow

1.1.4 Measurement range init

Input of beginning value of measurement range between 0 ... 100 %. Standard: 0.0.

With C you set the value to 0.0. With the numbers you input the beginning value and with \hookrightarrow the input is accepted and you quit the menu level.

Measurement range						
Init				7	8	9
0.0	%			4	5	6
	H ₂ O			1	2	3
				C	0	\hookrightarrow

1.1.5 Measurement range end

Input of end value of the measurement range between 0 ... 100 %. Standard: 0.0.

With C you set the value to 1.0. With the numbers you input the beginning value and with \hookrightarrow the input is accepted and you quit the menu level.

Measurement range						
End				7	8	9
80.0	%			4	5	6
	H ₂ O			1	2	3
				C	0	\hookrightarrow

1.1.6 Filter value

Setting of the damping time between (range between 0.1 ... 999.9 s).

With **C** you set the value to 0.0. With the numbers you input the beginning value and with **↵** the input is accepted and you quit the menu level.

Measurement range	7	8	9
Filter	4	5	6
1.0	1	2	3
s	C	0	↵

1.2 Alarm 1

With **↑** and **↓** you choose the menu point. With **C** you quit the menu point without any change and with **↵** the input is accepted and you arrive 1 menu point lower to make your settings.

1.2 Alarm 1		↑
1.2.1 Type	Minimum	↓
1.2.2 Value	1.0	C
1.2.3 Dead time	0.1 s	↵
1.2.4 Hysteresis	1.0 %	

1.2.1 Alarm type

Choose the limits:
Minimum / Maximum

With **↑** and **↓** you make a choice according to the display. With **C** you quit the menu point without any change and with **↵** the input is accepted and you arrive 1 menu point lower to make your settings.

Alarm 1	↑
Alarm type	↓
Minimum	C
	↵

1.2.2 Alarm value

Choose the response threshold of measurement end values in phys. unities. (range between 0 ... 100 %)

With **C** you set the value to 0.0. With the numbers you input the beginning value and with **↵** the input is accepted and you quit the menu level.

Alarm 1	7	8	9
Alarm value	4	5	6
10.0	1	2	3
% H₂O	C	0	↵

1.2.3 Alarm dead time

Choose the time, how long the value above and under the limit has to be, before the alarm relay switches. (range between 0.1 ... 99.9 s)

With **C** you set the value to 0.0. With the numbers you input the beginning value and with **↵** the input is accepted and you quit the menu level.

Alarm 1	7	8	9
Dead time	4	5	6
1.0	1	2	3
s	C	0	↵

1.2.4 Alarm hysteresis

Choose the value for clearing the alarm.
Range between 0.1 ... 99.9 % in the defined measurement range.

With **C** you set the value to 0.0. With the numbers you input the beginning value and with **↵** the input is accepted and you quit the menu level.

Alarm 1 Hysteresis 1.0 %	7	8	9
	4	5	6
	1	2	3
	C	0	↵

1.2.5 Operation modus

Choice of switching contact:
AST - Open current
RST - Closed current

With **↑** and **↓** you make a choice according to the display. With **C** you quit the menu point without any change and with **↵** the input is accepted and you arrive 1 menu point lower to make your settings.

Alarm 1 Operation modus AST	↑
	↓
	C
	↵

1.3 Alarm 2

According to Alarm 1

1.4 Calibration

With **↑** and **↓** you make a choice according to the display. With **C** you quit the menu point without any change and with **↵** the input is accepted and you arrive 1 menu point lower to make your settings.

1.4 Calibration		↑
1.4.1 Filter	0.1 s	↓
1.4.2 Base point	2	
1.4.3 Factor 1	1.00	C
1.4.4 Factor 2	0.00	
		↵

1.4.1 Calibration filter

Damping filter in order to slow down disturbed signals during the calibration (no effect on output and display);
Range between 0.1 ... 999.9 s

With **C** you set the value to 0.0. With the numbers you input the beginning value and with **↵** the input is accepted and you quit the menu level.

Calibration Filter 0.1 s	7	8	9
	4	5	6
	1	2	3
	C	0	↵

1.4.2 Number of calibration points

Enter the necessary number of base points (between 2 ... 5).

With **C** you set the value to 0.0. With the numbers you input the beginning value and with **↵** the input is accepted and you quit the menu level.

Calibration Base points 2	7	8	9
	4	5	6
	1	2	3
	C	0	↵

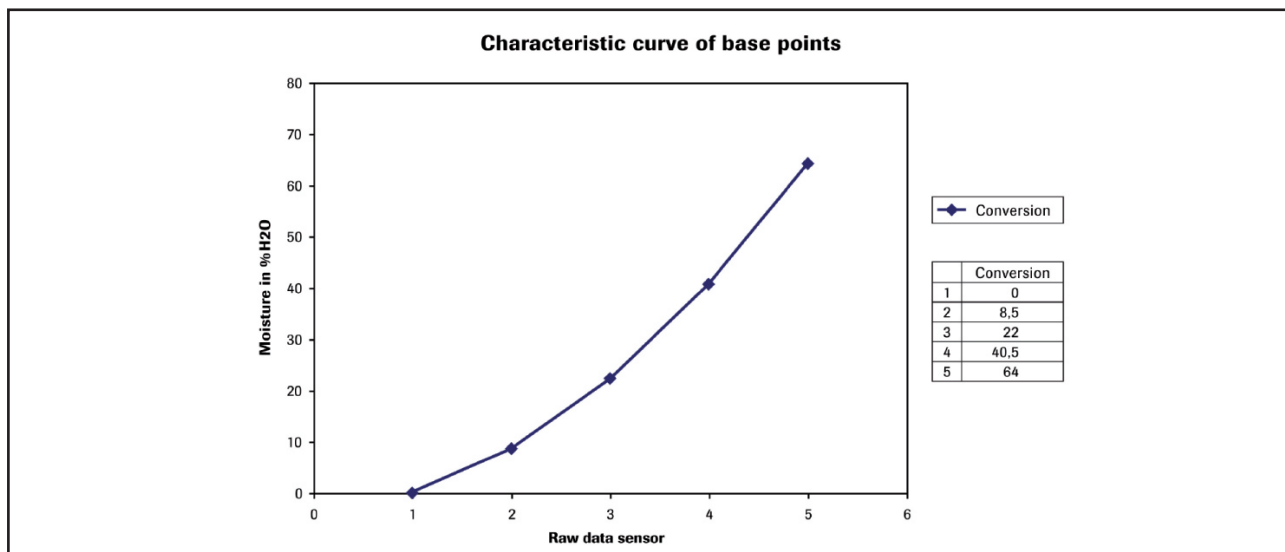

Only necessary in case of disturbing nonlinearity (see chart).
The base points of the ideal characteristic curve are entered and calibrated down to the actual characteristic curve. If the following adjustment is done, the signal output will be linear.

1.4.3 Calibration factor for sensor 1

Weighting of sensor signals by using several sensors; **Disconnection of a sensor with 0.**

With \uparrow and \downarrow you make a choice according to the display. With \square you quit the menu point without any change and with \leftarrow the input is accepted and you arrive 1 menu point lower to make your settings.

Calibration Factor 1	7	8	9
1.00	4	5	6
	1	2	3
	C	0	\leftarrow

1.4.4 Calibration factor for sensor 2

According to sensor 1.

1.4.5 Calibration factor for sensor 3

According to sensor 1.

1.4.6 Calibration point 1

Choose the measured value in physical unities - beginning and end of measurement range.

Calibration Calibration point 1	7	8	9
10.0 % H ₂ O	4	5	6
	1	2	3
	C	0	\leftarrow

1.4.7 Measured value

Input value is collected and assigned to the shown measured value.

Calibration Calibration point 1	
317.944	C
Akt.: 917.944	\leftarrow

1.4.8 Calibration point 2

Choose the measured value in physical unities - beginning and end of measurement range.

1.4.9 Measured value 2

Input value is collected and assigned to the shown measured value.

1.4.10 Calibration point N

... depends on the number of calibration points

1.4.11 Measured value

Input value is collected and assigned to the shown measured value.

For 2.1 to 2.4 / 3.1 to 3.4 / 4.1 to 4.4: analogue to point 1

5. Analogue output

With and you make a choice according to the display. With you quit the menu point without any change and with the input is accepted and you arrive 1 menu point lower to make your settings.

5. Analogue output	<input type="button" value="↑"/>
5.1 Beginning 4.0 mA	<input type="button" value="↓"/>
5.2 End 20.0 mA	<input type="button" value="C"/>
5.3 Minimum 0.3 mA	<input type="button" value="↵"/>
5.4 Maximum 21.0 mA	

5.1 Beginning of range

Choose the output in the range of 0 ... 22 mA (Standard 4 mA).

With you set the value to 0.0. With the numbers you input the beginning value and with the input is accepted and you quit the menu level.

Analogue output Range beginning	7	8	9
4.0 mA	4	5	6
	1	2	3
	C	0	↵

5.2 End of Range

Choose the output in the range of 0 ... 22 mA (Standard 20 mA).

With you set the value to 0.0. With the numbers you input the beginning value and with the input is accepted and you quit the menu level.

Analogue output Range end	7	8	9
20.0 mA	4	5	6
	1	2	3
	C	0	↵

5.3 MIN limit

Choose the minimal output value in the range of 0 ... 22 mA (Standard 3 mA).

With you set the value to 0.0. With the numbers you input the beginning value and with the input is accepted and you quit the menu level.

Analogue output MIN limit	7	8	9
3.0 mA	4	5	6
	1	2	3
	C	0	↵

5.4 MAX limit

Choose the minimal output value in the range of 0 ... 22 mA (Standard 20 mA).

With **C** you set the value to 0.0. With the numbers you input the beginning value and with **↵** the input is accepted and you quit the menu level.

Analogue output MAX limit 20.0 mA	7	8	9
	4	5	6
	1	2	3
	C	0	↵

5.5 Alarm value

Choose the output value for the alarm (sensor error or an internal alarm); at the same time the relay 3 drops down. Range of 0 ... 22 mA (Standard 3 mA)

With **C** you set the value to 0.0. With the numbers you input the beginning value and with **↵** the input is accepted and you quit the menu level.

Analogue output Alarm value 3.0 mA	7	8	9
	4	5	6
	1	2	3
	C	0	↵

5.6 Filter time

Choose the filter time for the **current output** in the range of 0.1 ... 999.9 s (Standard 1 s).

With **C** you set the value to 0.0. With the numbers you input the beginning value and with **↵** the input is accepted and you quit the menu level.

Analogue output Filter time 3.0 s	7	8	9
	4	5	6
	1	2	3
	C	0	↵

5.7 Calibration: 4 mA

Set the minimal current output. Fit to the external measurement system (at differing display).

Adapt the current output to 4 mA with the keys **<<<** and **>>>** quickly and with the keys **<** and **>** slowly. With **↵** the input is accepted and you quit the menu level, with **C** you quit the menu point without any change.

Analogue output Calibration 4.0 mA		
<<<	<	> >>>
		C ↵

5.8 Calibration: 20 mA

Set the maximal current output. Fit to the external measurement system (at differing display).

Adapt the current output to 4 mA with the keys **<<<** and **>>>** quickly and with the keys **<** and **>** slowly. With **↵** the input is accepted and you quit the menu level, with **C** you quit the menu point without any change.

Analogue output Calibration 20 mA		
<<<	<	> >>>
		C ↵

6. Digital inputs

It is only necessary for stopping and starting the measurement via an external control line (for wiring see 9)

With and you make a choice according to the display. With you quit the menu point without any change and with the input is accepted and you arrive 1 menu point lower to make your settings.

6. Digital inputs		
6.1 Digital input	1	
6.2 Digital input	2	

6.1 Digital input 1

With and you make a choice according to the display. With you quit the menu point without any change and with the input is accepted and you arrive 1 menu point lower to make your settings.

6.1 Digital input 1		
6.1.1 Function	none	
6.1.2 Direction	direct	
6.1.3 Filter	1.0 s	

6.1.1 Function

No function /M-Stop /Product choice -Start / Stop of the device via external control signal.

With and you make a choice according to the display. With you quit the menu point without any change and with the input is accepted and you quit the menu level.

Digital input 1 Function	
none	

6.1.2 Effect direction

Direct / inverted

With and you make a choice according to the display. With you quit the menu point without any change and with the input is accepted and you quit the menu level.

Digital input 1 Effect direction	
direct	

6.1.3 Filter

Dead time after activating (for debouncing of mechanical switching contacts).
Range of 0 ... 99.9 s

With you set the value to 0.0. With the numbers you input the beginning value and with the input is accepted and you quit the menu level.

Digital input 1 Filter	7	8	9
1.0 s	4	5	6
	1	2	3
		0	

6.2 Digital input 2 - analogue to digital input 1

7. System

Setting of the ModBus interface parameters when connecting to the system bus.

With and you make a choice according to the display. With you quit the menu point without any change and with the input is accepted and you arrive 1 menu point lower to make your settings.

7. System		
7.1 Baud rate	9600	
7.2 Address	1	
7.3 Contrast		
7.4 Language	D	

7.1 Baud rate

Choice of baud rate between 4800 / 9600 / 19200 / 38400 Bd

With and you make a choice according to the display. With you quit the menu point without any change and with the input is accepted and you quit the menu level.

System	
Baud rate	
9600	

7.2 ModBus Address

ModBus address in RTU-Mode (slave). Address range 1 ... 255.

With you set the value to 0. With the numbers you input the beginning value and with the input is accepted and you quit the menu level.

System	7	8	9
Address	4	5	6
1	1	2	3
	C	0	

7.3 Contrast

Display contrast for a better legibility.

Adapt the contrast to desired value with the keys and quickly and with the keys and slowly. With the input is accepted and you quit the menu level, with you quit the menu point without any change.

System contrast		

7.4 Language

Choose of language between: D / F / E

With and you make a choice according to the display. With you quit the menu point without any change and with the input is accepted and you quit the menu level.

System	
Language	
D	

7.5 Backlight

Setting of durable lightning or the luminescence (in min). Zero corresponds to permanent lighting.

With you set the value to 0 (equals to durable lightning) by means of the numbers and with the input is accepted and the menu level is quitted.

System	7	8	9
Backlight	4	5	6
0 min	1	2	3
	C	0	

7.6 Display temperature

Determine if the temperature is shown in the display - the values are on and off.

The temperature of the sensor is not available via current output. This value do not represents the temperature of the product.

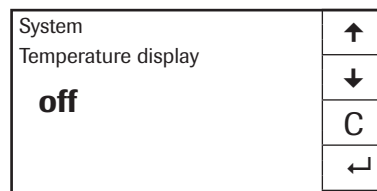

With and you make a choice according to the display. With you quit the menu point without any change and with the input is accepted and you quit the menu level.

8. Storage

Only with change and leaving the menu level.

With leave the menu without any change, with transfer the entry and leave the menu level.

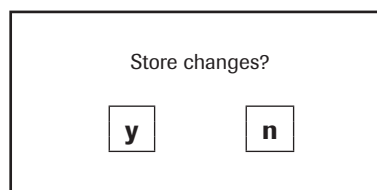

9. Wiring Example

Digital input

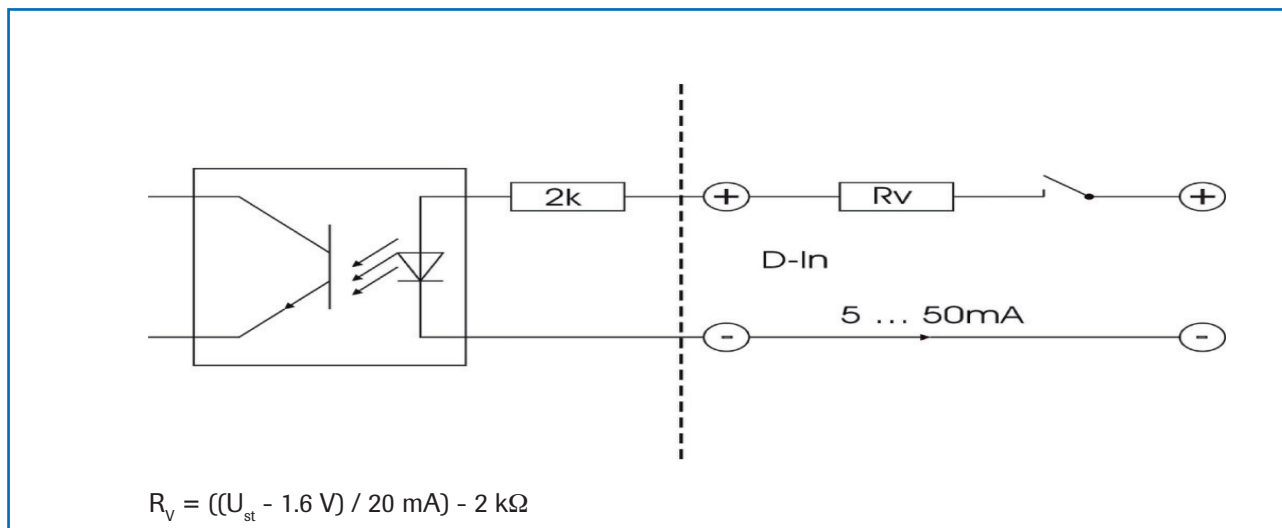

10. Maintenance



Warning!

- Danger shock with open housing!
- Switch off the power supply for all maintenance or repair works on the measuring system. The tube must not be in operation during a sensor exchange.
- Repair and maintenance work must be carried out by trained or expert personnel only.
- The system is maintenance-free.

11. Warranty

Warranty is granted for one year starting from delivery date under the condition that the operating instructions have been followed, no interventions on the appliances have been made and the components of the system show no mechanical damage or wear resistance.

In case of a defect during the warranty period, defective components are repaired or are replaced free of charge. Replaced parts turn into the property of SWR. If desired by the customer that the parts should be repaired or replaced in its factory, then the customer has to take over the costs for the SWR-service staff.

SWR is not responsible for damage, which did not develop at the delivery article; especially SWR is not responsible for escaped profit or other financial damages of the customer.

12. Trouble Shooting



- **Warning!**
The electrical installation must only be checked by expert personnel.

Problem	Cause	Measure
Measuring system does not work.	Power supply interrupted.	Check the power supply.
	Cable break.	Check the connecting cables for a possible break of a cable.
	Defective fuse.	Exchange the fuse in the field housing.
	Defective device.	Call SWR for further instructions.
Measuring system outputs wrong values.	Incorrect calibration.	Delete input signal correction, new calibration according to section 7.
	Calibration shifted by abrasion or caking on front end of sensor.	Delete input signal correction, new calibration according to section 7.
Sensor error.	Sensor not properly connected.	Check cable.
	Sensor damaged.	Replace sensor.
	No 24 V DC supply on sensor.	Assure right power supply.
Relay flickering.	Hysteresis too small.	Increase hysteresis, check effects caused by external devices.

Do not open, as otherwise the warranty claim expires!

13. Technical Data

Sensor	
Housing	Stainless steel 1.4571
Sensor surface	Ceramic
Ex-protection (optional)	Zone 0 (gas), Zone 20 (dust)
Protection category	IP 67 according to EN 60529
Material ambient temperature	0 ... +120 °C
Working pressure	Max. 10 bar
Power consumption	0.6 W
Response time	0.1 s
Weight	Approx. 1000 g
Measuring range	0 ... 65 % residual moisture (depending on material)
Accuracy	0.1 % absolutely in the calibrated measuring range
Connection cable	Shielded cable 4-wired, 0.25 mm ²
Transmitter	
Power supply	110 / 230 V AC (50 Hz) / 24 V DC
Power consumption	20 W / 24 V
Current consumption	Max. 1 A at 24 V
Protection category	IP 65 according to EN 60529/10.91
Operating temperature	-10 ... +45 °C
Dimensions	258 x 237 x 174 (W x H x D)
Weight	Approx. 2.5 kg
Interface	RS 232, RS 485
Cable glands	3 x M16 (4.5 - 10 mm Ø)
Cable cross section	0.2 - 2.5 mm ² [AWG 24-14]
Current output signal	1 x 4 ... 20 mA (0 ... 20 mA), load < 500 Ω
Switched output measuring alarm	Relay with two-way contact - max. 250 V AC, 1 A
Digital inputs	2 inputs for active external control signals
Data protection	Flash