

DA09 || Differential Pressure Gauge

The Model DA09 is designed for measurement of differential pressures of liquids and gases. It can be fitted with a choice optional accessories, including:

- Limit detector contacts: delayed-action or magnet actuated switch type
- Non-contact proximity type limit detector (NAMUR)

Principles of Operation

The pressures to be compared are connected to adjacent pressure chambers separated by a flexible metal diaphragm. The diaphragm is loaded by a pair of opposing coaxial bellows springs, one on either side of the diaphragm. The bellows on one side also serves to isolate the surrounding pressure chamber from the gauge mechanism, thus protecting the mechanism from the media. A connecting rod links the diaphragm, through the isolating spring bellows, to the dial mechanism.

When pressures on both sides of the diaphragm are equal, the diaphragm is at zero deflection. When there is a pressure difference between the two chambers, the diaphragm is deflected away from the higher pressure chamber, towards the lower pressure chamber. The resulting linear displacement of the connecting rod is translated into angular movement of the gauge's dial pointer, through a precision mechanism. The angular movement of the pointer is proportional to the pressure difference across the diaphragm.

Schematic Diagram

- 1 Sensing diaphragm
- 2 Sealing / spring bellows
- 3 Connecting rod
- 4 Pointer mechanism

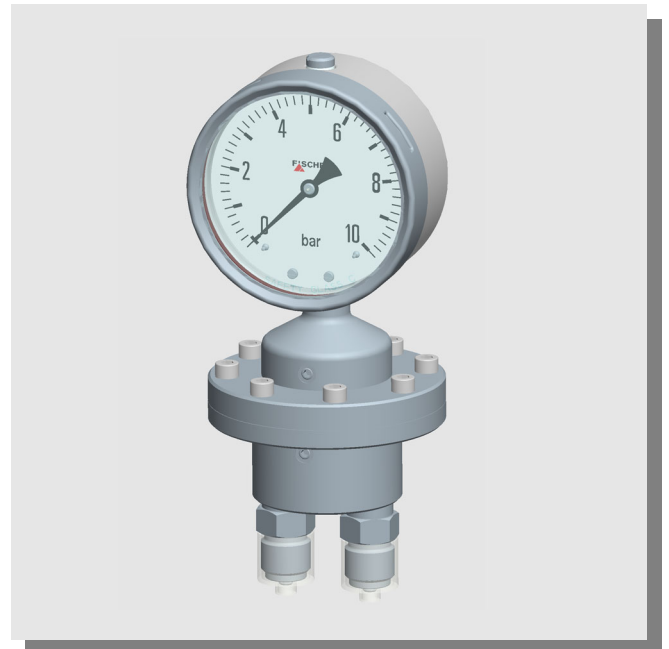

Features

- Corrosion resistant
- Choice of pressure connection types
- Compatible with aggressive media

Applications

- Chemical, pharmaceutical industries
- Process industries
- Marine and off-shore

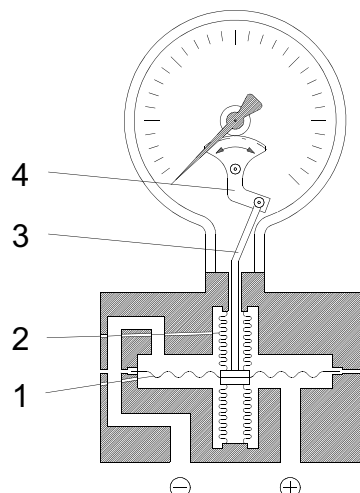

Specifications

General	Ranges / max. static pressure	0...25 mbar to 0...250 mbar / 10 bar 400 mbar to 0...25 bar / 25 bar
	Accuracy	± 2.5% FS
	Max. differential overpressure	Either side: 10 x FS
	Indicator	Circular dial type, 100mm or 160mm diameter, safety housing DIN EN 837 NG 100 o. NG 160
	Operating temperature	Ambient: -20°C to +80°C Medium: +100°C, maximum
	Temperature coefficient	Approx. 0.3% / 10K
	Zero adjustment	By screw on top of gauge housing, ±25% FS
	Protection class	IP 54, per DIN EN 60529
Pressure connections	Threaded sockets 2x G $\frac{1}{4}$ (F); plus other optional types (see Ordering Code)	
Materials	Pressure chambers (media contact)	Stainless steel 1.4404 (AISI 316L)
	Diaphragm (media contact)	Ranges ≤ 400mbar: stainless steel 1.4571 (AISI 316Ti) Ranges ≥ 0.6 bar: DURATHERM® (stainless steel)
	Bellows (media contact)	Stainless steel 1.4571
	Pointer mechanism	Stainless steel 1.4301
	Dial housing	Stainless steel 1.4301
	Dial window	Laminated safety glass
	Dial scale and pointer	Aluminium
	O-ring seals	FPM (fluorocarbon elastomer)
Options and Accessories	Electrical accessories	Limit signalling contacts: delayed action / magnet actuated switch type / non-contact proximity type limit detector. Pointer rotation transducer: capacitance type, with output signal proportional to the pointer position (uses deeper gauge housing: see Dimensions) For details of electrical accessories, see Data Sheet KE. Accessories applicable on ranges ≥ 100 mbar
	Liquid filling	For operating conditions involving vibration, pressure fluctuations, and/or moisture condensation inside, the gauge can be supplied with glycerine filling. Instruments with build-in contacts will be filled with NAPVIS for better electrical isolation. In case of inductive contacts silicon oil will be used.
	Reference pointer	Adjustable pointer for visual marking of limit / reference values
	Peak registering pointer	Separate pointer without spring, friction holding: dragged by the measuring pointer as the measured value increases. Stays put when the measuring value recedes, thereby registering peak value. Manual re-setting (Range ≥ 60 mbar).
	O ₂ - applications „degreased“	According to German „BG-Chemie“ regulations all wetted parts will be degreased. (See ordering code 3 at item „Dial liquid filling“)
Options (on request)	Options (on request)	Special dial scales, housing material: stainless steel 1.4571
	Accessories	Blocking / equalising valves unit, models DZ 93/94: Three and four spindle types. For zero calibration, static pressure testing, and sealing pressure source when removing gauge for servicing. The fourth spindle in the model DZ 94 can be used to vent the pressure source.
Mounting	pipe fitting	On pressure connections
	wall mounting pipe mounting	With mounting plate With mounting plate and fastening bow
		Pressure connection by means of threaded cutting ring connectors or direct fitted pressure lines should be carried out with appropriate jointing compound.

Dimensions (all units in mm unless stated otherwise)

for ranges 0.4...25 bar

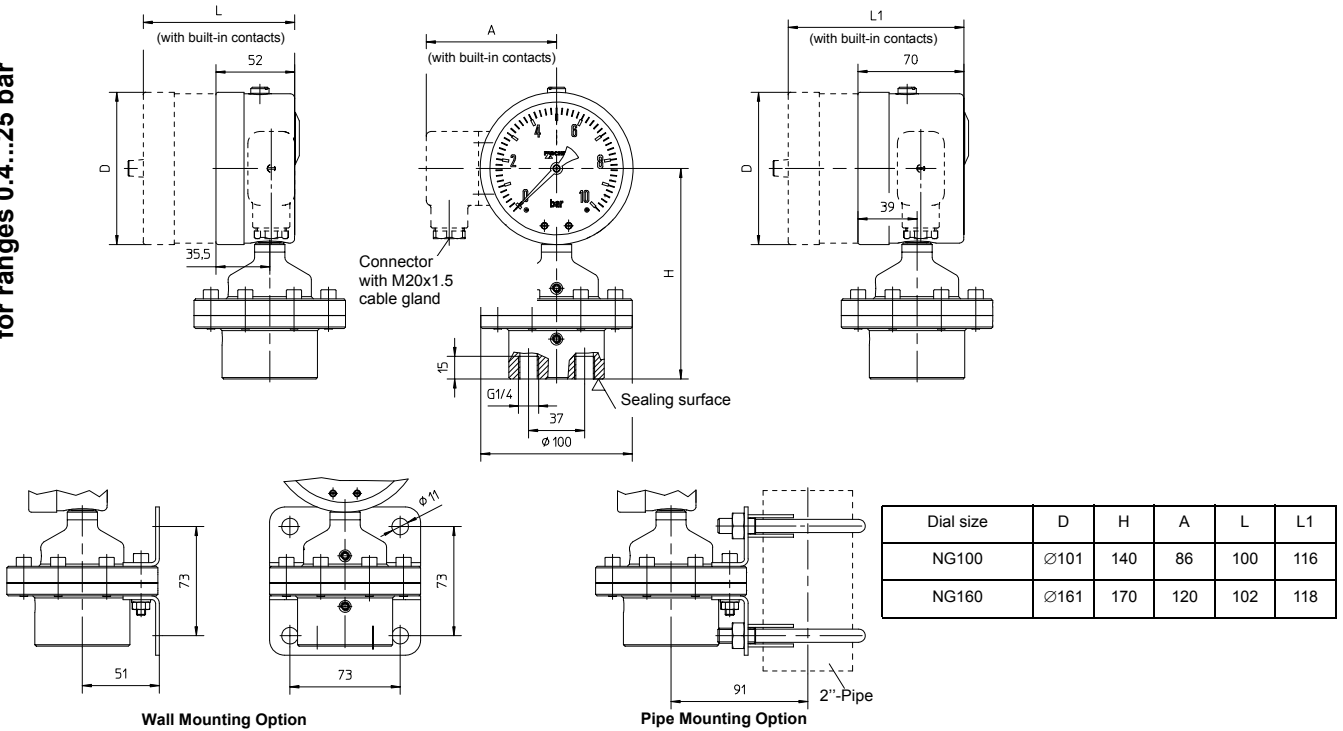

for ranges 25...250 mbar

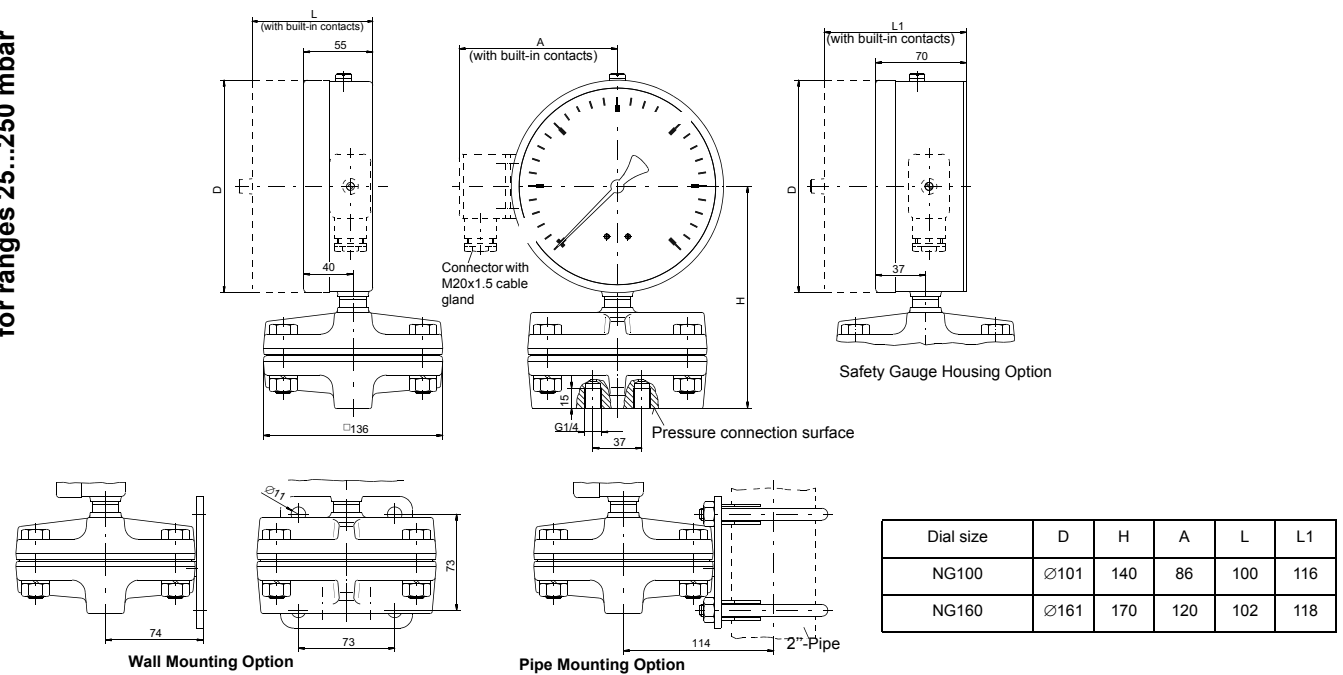

Connections

outside threading G	L	L1	SW
G 1/4	25	12	19
G 1/2	34	17	22
1/4-18 NPT	30	12	19
1/2-14 NPT	37	13	22

inside threading G	L	L1	SW
G 1/2	26	19	27
1/4-18 NPT	20	-	19
1/2-14 NPT	26	-	27

Option: Three spindle blocking valve DZ 93
or
Four spindle blocking valve DZ 94

